

# MURRAY

## MURRAY CORPORATION Clamping Solutions



**MURRAY**

260 Schilling Circle  
Hunt Valley, MD, 21031, USA

Ph: 410-771-0380 • Fax: 410-771-5576  
www.murraycorp.com • email: sales@murraycorp.com





**MURRAY**

# MURRAY CORPORATION

## Clamping Solutions

# Index

Choose your clamp for more information



Worm Drive Hose Clamps - SAE Type "F"  
Embossed Worm Gear Hose Clamps  
HDL High Torque Series Clamps - SAE Type "F"  
Constant Tension Turbo Seal Clamps - SAE Type "T"  
Dual Bead Super Sealing Clamp - SAE Type "F"  
5/16" Wide Worm Drive Clamp - SAE Type "M" Mini Series  
Double-Wire Clamps - SAE Type "A"  
Keystone Pinch Clamp (Welded) - SAE Type "J" (KS)  
Keystone Pinch Clamp (Mechanical) - SAE Type "J" (KSC)  
Seamless Pinch Clamps (KVG T)  
Heavy Duty Seamless PEX Pipe Clamps For use with "DZR" Brass and Plastic PEX Fittings  
Everlast 20 Heavy Duty Seamless Clamps  
"Create-A-Clamp" Clamp Making Kit  
T-Bolt Clamps - SAE Type "TB"  
Spring-Loaded T-Bolt Clamps - SAE Type "SLTB"  
Quick Release Clamps

Flexible Clamp Driver"/Nut Runner & Clamp Key  
Murray Clamp Crimping Tools  
Tri Gage Diameter and Thread Pitch Tool  
Split Die Thread Repair Tool



**MURRAY**

260 Schilling Circle • Hunt Valley, MD, 21031, USA — Ph: 410-771-0380 • Fax: 410-771-5576

[www.murraycorp.com](http://www.murraycorp.com) • email: [sales@murraycorp.com](mailto:sales@murraycorp.com)

# MURRAY

# MURRAY CORPORATION Clamping Solutions

## Worm Drive Hose Clamps - SAE Type "F"

Murray is a manufacturer of multiple grades and sizes of traditional Worm Drive hose clamps. Our SAE type F clamps have all stainless steel bands and housings. A Murray tradition for over 90 years.

### H Series – "Gold Seal"® Clamps

Band and housing are 200/300 series stainless steel. Screw is 5/16" slotted hex head, heat treated carbon steel, plated with zinc plus trivalent chromate for long lasting protection. Good general-purpose clamp.

### HSS Series – With "400" Series Steel Screw Clamps

Band and housing are 200/300 series stainless steel. Screw is 5/16" slotted hex head, heat treated 400 series stainless steel. The corrosion resistance of this all stainless steel band, housing and screw makes this the perfect clamp for numerous industrial installations.

### HFSS Series - All "300" Series Stainless Steel Construction Clamps

Band, housing and screw are 300 series stainless steel. Screw is 5/16" slotted hex head. The all-300 series stainless steel construction provides better corrosion resistance than that available from the "H-SS" Series, making this worm drive clamp well suited for marine applications.



#### Rated Ultimate Torque:

Carbon Screw 50in.lbs. min. (5.6Nm)  
SS Screw 60in.lbs. min. (6.8Nm)

#### Recommended Installation Torque:

Carbon Screw 30-40in.lbs. (3.4 - 4.5Nm)  
SS Screw 35-45in.lbs. (4.0 - 5.1Nm)

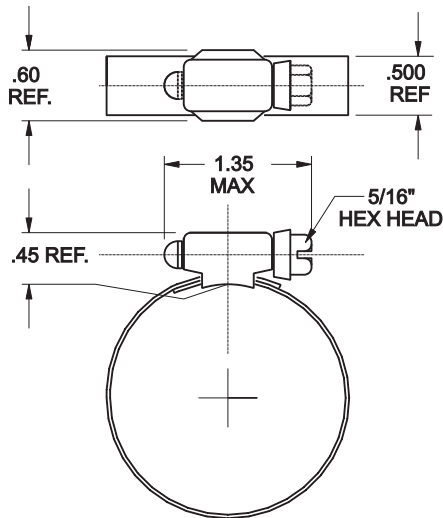

Applies to: H, H-SS, HF-SS Series



**MURRAY**  
Clamp  
Key

Clamp Series "A"				Diameter Range SAE					
Size	H	H-SS	HF-SS	Decimals		Inches		Millimeters	
6	H 6	H 6 SS	HF 6 SS	.44	.78	7/16	25/32	11	20
8	H 8	H 8 SS	HF 8 SS	.44	.91	7/16	29/32	11	23
10	H 10	H 10 SS	HF 10 SS	.56	1.06	9/16	1-1/16	14	27
12	H 12	H 12 SS	HF 12 SS	.69	1.25	11/16	1-1/4	18	32
16	H 16	H 16 SS	HF 16 SS	.75	1.50	3/4	1-1/2	19	38
20	H 20	H 20 SS	HF 20 SS	.81	1.75	13/16	1-3/4	21	44
24	H 24	H 24 SS	HF 24 SS	1.06	2.00	1-1/16	2	27	51
28	H 28	H 28 SS	HF 28 SS	1.31	2.25	1-5/16	2-1/4	33	57
32	H 32	H 32 SS	HF 32 SS	1.56	2.50	1-9/16	2-1/2	40	64
36	H 36	H 36 SS	HF 36 SS	1.81	2.75	1-13/16	2-3/4	46	70
40	H 40	H 40 SS	HF 40 SS	2.06	3.00	2-1/16	3	52	76
44	H 44	H 44 SS	HF 44 SS	2.31	3.25	2-5/16	3-1/4	59	83
48	H 48	H 48 SS	HF 48 SS	2.56	3.50	2-9/16	3-1/2	65	89
52	H 52	H 52 SS	HF 52 SS	2.81	3.75	2-13/16	3-3/4	71	95
56	H 56	H 56 SS	HF 56 SS	3.06	4.00	3-1/16	4	78	102
60	H 60	H 60 SS	HF 60 SS	3.31	4.25	3-5/16	4-1/4	84	108
64	H 64	H 64 SS	HF 64 SS	3.56	4.50	3-9/16	4-1/2	90	114
72	H 72	H 72 SS	HF 72 SS	4.06	5.00	4-1/16	5	103	127
80*	H 80	H 80 SS	HF 80 SS	4.56	5.50	4-9/16	5-1/2	116	140
88*	H 88	H 88 SS	HF 88 SS	5.06	6.00	5-1/16	6	129	152
96	H 96	H 96 SS	HF 96 SS	5.56	6.50	5-9/16	6-1/2	141	165
104	H 104	H 104 SS	HF 104 SS	6.06	7.00	6-1/16	7	154	178
116	H 116	H 116 SS	HF 116 SS	6.50	7.75	6-1/2	7-3/4	165	197
128	H 128	H 128 SS	HF 128 SS	5.69	8.50	5-11/16	8-1/2	144	216



Other sizes available upon request. Available in packed and bulk stock. Other packaging configurations available.  
\*items not stocked. Subject to availability.



**MURRAY**

260 Schilling Circle  
Hunt Valley, MD, 21031, USA

Ph: 410-771-0380 • Fax: 410-771-5576

www.murraycorp.com • email: sales@murraycorp.com

## Embossed Worm Gear Hose Clamps

- Embossed worm drive clamps to the DIN 3017 standard.
- General purpose non perforated band especially suited for most hoses and soft silicone hose.
- Material and clamp size range is stamped on the band.
- Protects hose from shearing and fraying.
- Now available in the all 304 SS steel (W4) and in the popular 316SS (W5) grade steel. Ask your salesperson about the availability of the W1, W2 material grades. Available in 9mm and 12mm wide band.
- Common applications: Vehicular, industrial, mechanical engineering, plumbing & marine

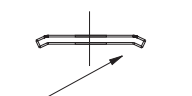
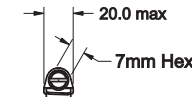
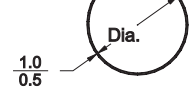
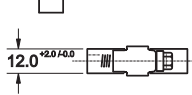
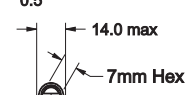
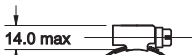
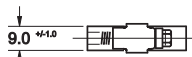

Edge Detail

### 9mm Wide Embossed Band Clamps

W4 Mat'l Part Number	W5 Mat'l Part Number	Range of Adjust (mm)	Suggested Installation Torque (in-lbs)
EB9x012SS	EBL9x012SS	8-12	20.0
EB9x016SS	EBL9x016SS	10-16	20.0
EB9x018SS	EBL9x018SS	12-18	20.0
EB9x022SS	EBL9x022SS	12-22	30.0
EB9x027SS	EBL9x027SS	16-27	30.0
EB9x032SS	EBL9x032SS	20-32	30.0
EB9x040SS	EBL9x040SS	25-40	30.0
EB9x045SS	EBL9x045SS	30-45	30.0
EB9x050SS	EBL9x050SS	32-50	30.0
EB9x060SS	EBL9x060SS	40-60	30.0
EB9x070SS	EBL9x070SS	50-70	30.0
EB9x080SS	EBL9x080SS	60-80	30.0
EB9x090SS	EBL9x090SS	70-90	30.0
EB9x100SS	EBL9x100SS	80-100	30.0
EB9x110SS	EBL9x110SS	90-110	30.0
EB9x120SS	EBL9x120SS	100-120	30.0
EB9x130SS	EBL9x130SS	110-130	30.0
EB9x140SS	EBL9x140SS	120-140	30.0
EB9x150SS	EBL9x150SS	130-150	30.0
EB9x160SS	EBL9x160SS	140-160	30.0

### 12mm Wide Embossed Band Clamps

W4 Mat'l Part Number	W5 Mat'l Part Number	Range of Adjust (mm)	Suggested Installation Torque (in-lbs)
EB12x027SS	EBL12x027SS	16-27	35.0 - 45.0
EB12x032SS	EBL12x032SS	20-32	35.0 - 45.0
EB12x040SS	EBL12x040SS	25-40	35.0 - 45.0
EB12x045SS	EBL12x045SS	30-45	35.0 - 45.0
EB12x050SS	EBL12x050SS	32-50	35.0 - 45.0
EB12x060SS	EBL12x060SS	40-60	35.0 - 45.0
EB12x070SS	EBL12x070SS	50-70	35.0 - 45.0
EB12x080SS	EBL12x080SS	60-80	35.0 - 45.0
EB12x090SS	EBL12x090SS	70-90	35.0 - 45.0
EB12x100SS	EBL12x100SS	80-100	35.0 - 45.0
EB12x110SS	EBL12x110SS	90-110	35.0 - 45.0
EB12x120SS	EBL12x120SS	100-120	35.0 - 45.0
EB12x130SS	EBL12x130SS	110-130	35.0 - 45.0
EB12x140SS	EBL12x140SS	120-140	35.0 - 45.0
EB12x150SS	EBL12x150SS	130-150	35.0 - 45.0
EB12x160SS	EBL12x160SS	140-160	35.0 - 45.0



# MURRAY

# MURRAY CORPORATION Clamping Solutions

## HDL High Torque Series Clamps - SAE Type "F"

Murray Corporation precision-engineered specialty clamps for various applications. OEM quantities are available directly from Murray.

All 316 series stainless steel clamp. 1/2" inch wide band is thicker than standard worm drive clamp. This construction yields superior performance and longevity in corrosive environments. Applications include plumbing, water well, municipal storm drain systems, irrigation, marine, transportation and petro-chemical.

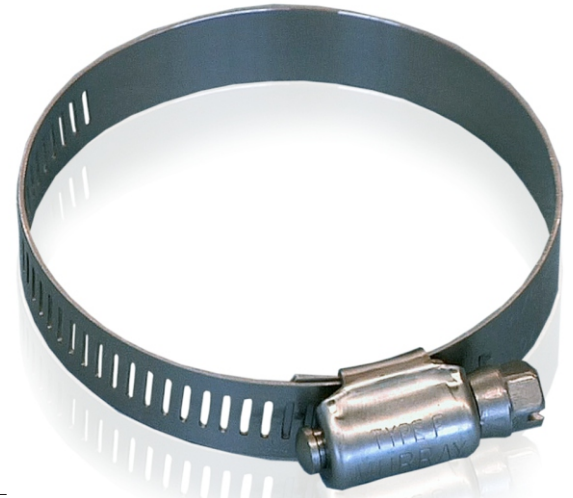
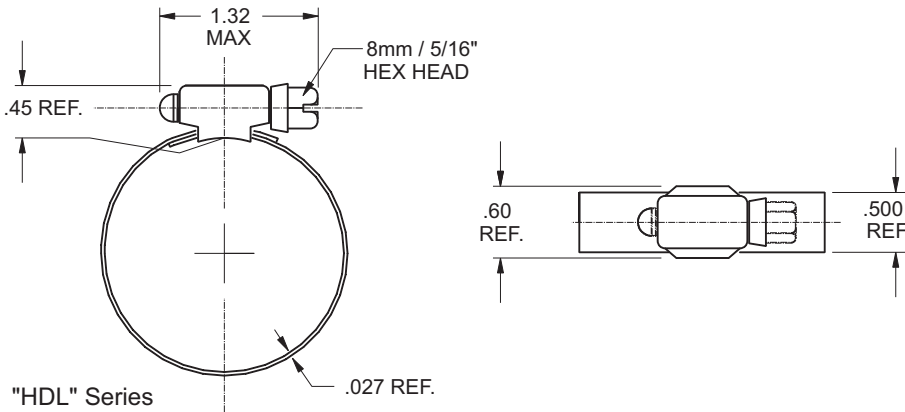

**Rated Ultimate Torque:**  
316 Stainless Screw 87in.lbs. min. (9.8Nm)  
**Recommended Installation Torque:**  
316 Stainless Screw 45-65in.lbs. (5.1 - 7.3Nm)

SAE Size	Part Number	"A" Diameter Range					
		Decimals		Inches		Millimeters	
6	HDL 6SS	.44	.78	7/16	25/32	11	20
8	HDL 8SS	.44	.91	7/16	29/32	11	23
10	HDL 10SS	.56	1.06	9/16	1-1/16	14	27
12	HDL 12SS	.69	1.25	11/16	1-1/4	18	32
16	HDL 16SS	.75	1.50	3/4	1-1/2	19	38
20	HDL 20SS	.81	1.75	13/16	1-3/4	21	44
24	HDL 24SS	1.06	2.00	1-1/16	2	27	51
28	HDL 28SS	1.31	2.25	1-5/16	2-1/4	33	57
32	HDL 32SS	1.56	2.50	1-9/16	2-1/2	40	64
36	HDL 36SS	1.81	2.75	1-13/16	2-3/4	46	70
40	HDL 40SS	2.06	3.00	2-1/16	3	52	76
44	HDL 44SS	2.31	3.25	2-5/16	3-1/4	59	83
48	HDL 48SS	2.56	3.50	2-9/16	3-1/2	65	89
52	HDL 52SS	2.81	3.75	2-13/16	3-3/4	71	95
56	HDL 56SS	3.06	4.00	3-1/16	4	78	102
60	HDL 60SS	3.31	4.25	3-5/16	4-1/4	84	108
64	HDL 64SS	3.56	4.50	3-9/16	4-1/2	90	114
72	HDL 72SS	4.06	5.00	4-1/16	5	103	127
80	HDL 80SS	4.56	5.50	4-9/16	5-1/2	116	140
88	HDL 88SS	5.06	6.00	5-1/16	6	129	152
96	HDL 96SS	5.56	6.50	5-9/16	6-1/2	141	165
104	HDL 104SS	6.06	7.00	6-1/16	7	154	178
116	HDL 116SS	6.50	7.75	6-1/2	7-3/4	165	197



HDL clamp sizes are available on special order only. Ask your Murray representative for price and availability.



260 Schilling Circle  
Hunt Valley, MD, 21031, USA

Ph: 410-771-0380 • Fax: 410-771-5576  
www.murraycorp.com • email: sales@murraycorp.com

# MURRAY

# MURRAY CORPORATION Clamping Solutions

## Constant Tension Turbo Seal Clamps - SAE Type

A constant tension worm gear clamp designed to compensate for the effects of thermal cycling and/or compression set of hose. Turbo Seal provides dual spring action through convoluted spring action band and spring characteristic of the "Dual Bead Shield." Electropolishing improves weld strength, which leads to improved performance, improved corrosion resistance, and enhances appearance with a more even finish. This clamp is used in automotive, off-highway, agriculture, heavy duty, aircraft (non-flight critical applications only), and military industries and can be found on turbo chargers, tanks, air-to-air, cooling and fuel lines. The unique "Dual Bead Shield" inner liner also concentrates band-sealing pressure, increasing performance up to 30% compared to standard smooth liners. Flanged edges protect soft hose compounds.

### Turbo-Seal Material Specifications

**Band Material:** Special proprietary grade of stainless with excellent spring properties

**Housing Material:** 300 Series Stainless

**Shield Material:** 300 Series Stainless

**Screw Material:** 300 Series Stainless



### Rated Ultimate Torque:

75in.lbs. min. (8.5Nm)

### Recommended Installation Torque:

50in.lbs. (5.6Nm)

Part Number	Diameter Range SAE							
	"300" Series		Decimals		Inches		Millimeters	
<b>Stainless Screws</b>								
TSS 14S30 EP	1.12	1.50	1-1/8	1-1/2	28	38		
TSS 16S30 EP	1.20	1.63	1-1/5	1-5/8	30	41		
*TSS 18S30 EP	1.28	1.75	1-1/4	1-3/4	33	44		
TSS 20S30 EP	1.37	1.88	1-3/8	1-7/8	35	48		
*TSS 24S30 EP	1.56	2.13	1-9/16	2-1/8	40	54		
TSS 28S30 EP	1.63	2.38	1-5/8	2-3/8	41	60		
TSS 32S30 EP	1.80	2.63	1-13/16	2-5/8	46	67		
TSS 36S30 EP	1.97	2.88	1-31/32	2-7/8	50	73		
TSS 40S30 EP	2.25	3.13	2-1/4	3-1/8	57	79		
TSS 44S30 EP	2.50	3.38	2-1/2	3-3/8	64	86		
TSS 48S30 EP	2.75	3.63	2-3/4	3-5/8	70	92		
*TSS 52S30 EP	3.00	3.88	3	3-7/8	76	98		
*TSS 56S30 EP	3.25	4.13	3-1/4	4-1/8	83	105		
*TSS 60S30 EP	3.50	4.38	3-1/2	4-3/8	89	111		
TSS 64S30 EP	3.75	4.63	3-3/4	4-5/8	95	118		
*TSS 68S30 EP	4.00	4.88	4	4-7/8	102	124		
*TSS 72S30 EP	4.25	5.13	4-1/4	5-1/8	108	130		
*TSS 76S30 EP	4.50	5.38	4-1/2	5-3/8	114	137		
*TSS 80S30 EP	4.75	5.63	4-3/4	5-5/8	121	143		
*TSS 84S30 EP	5.00	5.88	5	5-7/8	127	149		
*TSS 88S30 EP	5.25	6.13	5-1/4	6-1/8	133	156		
*TSS 92S30 EP	5.50	6.38	5-1/2	6-3/8	140	162		
*TSS 96S30 EP	5.75	6.63	5-3/4	6-5/8	146	168		
*TSS 104S30 EP	6.25	7.13	6-1/4	7-1/8	159	181		
*TSS 112S30 EP	6.75	7.63	6-3/4	7-5/8	172	194		
*TSS 116S30 EP	7.00	7.88	7	7-7/8	178	200		
*TSS 120S30 EP	7.25	8.13	7-1/4	8-1/8	184	206		

Other sizes available upon request. Available in packed and bulk stock. Other packaging configurations available.

\*items not stocked. special order only

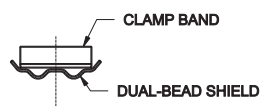
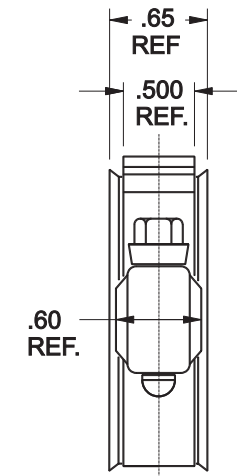

SECT. B-B

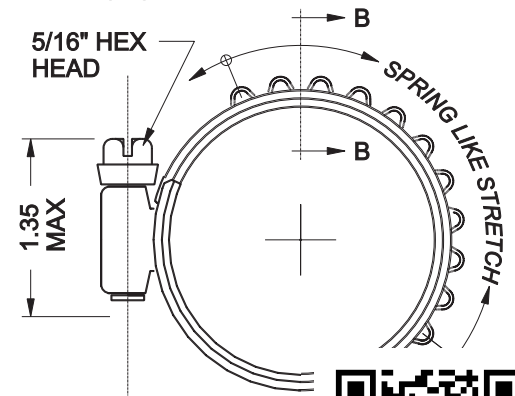

260 Schilling Circle  
Hunt Valley, MD, 21031, USA

Ph: 410-771-0380 • Fax: 410-771-5576

www.murraycorp.com

email: sales@murraycorp.com

# MURRAY

# MURRAY CORPORATION Clamping Solutions

## Dual Bead Super Sealing Clamp - SAE Type "F"

Murray Corporation precision-engineered specialty clamps for various applications. OEM quantities are available directly from Murray.

For air - air & coolant systems. The inner shield provides superb sealing characteristics and is safe for all soft hoses. It can also be found in the marine, agriculture, construction and off-highway markets.



Patented Product

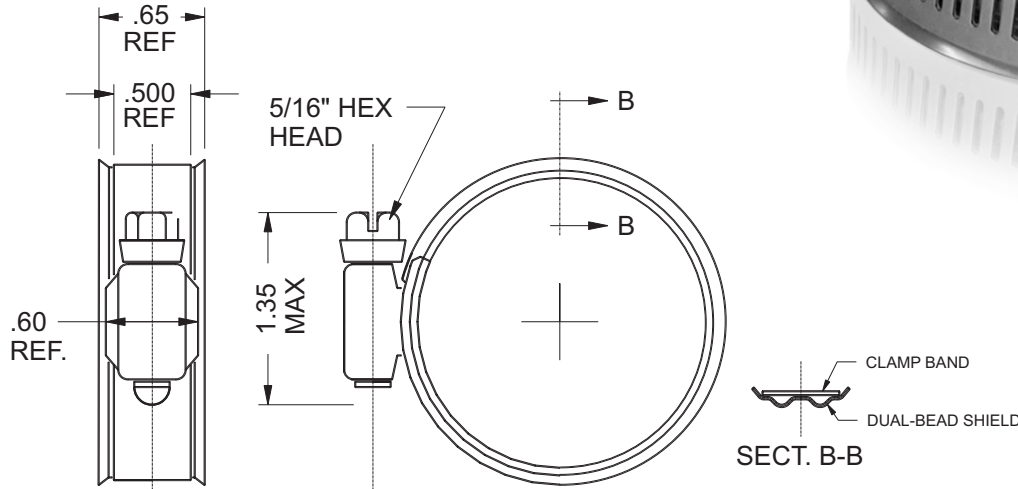

### Rated Ultimate Torque:

Carbon Screw 50in.lbs. min. (5.6Nm)  
SS Screw 60in.lbs. min. (6.8Nm)

### Recommended Installation Torque:

Carbon Screw 30-40in.lbs. (3.4 - 4.5Nm)  
SS Screw 35-45in.lbs. (4.0 - 5.1Nm)

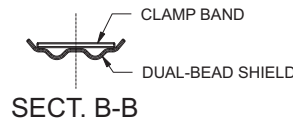

Plated Screws	Part Number		"A" Diameter Range					
	"400" Series	"300" Series	Decimals		Inches		Millimeters	
	Stainless Screws	Stainless Screws	Min.	Max.	Min.	Max.	Min.	Max.
DB 16	DB 16SS	DB 16SS305	0.63	1.38	5/8	1-3/8	15.9	34.9
DB 20	DB 20SS	DB 20SS305	0.69	1.63	11/16	1-5/8	17.5	41.4
DB 24	DB 24SS	DB 24SS305	0.94	1.88	15/16	1-7/8	23.8	47.6
DB 28	DB 28SS	DB 28SS305	1.19	2.13	1-3/16	2-1/8	30.2	54.0
DB 32	DB 32SS	DB 32SS305	1.44	2.38	1-7/16	2-3/8	36.5	60.3
DB 36	DB 36SS	DB 36SS305	1.69	2.63	1-11/16	2-5/8	42.9	66.7
DB 40	DB 40SS	DB 40SS305	1.94	2.88	1-15/16	2-7/8	49.2	73.0
DB 44	DB 44SS	DB 44SS305	2.19	3.13	2-3/16	3-1/8	55.6	79.4
DB 48	DB 48SS	DB 48SS305	2.44	3.38	2-7/16	3-3/8	61.9	85.7
DB 52	DB 52SS	DB 52SS305	2.69	3.63	2-11/16	3-5/8	68.3	92.1
DB 56	DB 56SS	DB 56SS305	2.94	3.88	2-15/16	3-7/8	74.6	98.4
DB 60	DB 60SS	DB 60SS305	3.19	4.13	3-3/16	4-1/8	81.0	104.8
DB 64	DB 64SS	DB 64SS305	3.44	4.38	3-7/16	4-3/8	87.3	111.1
DB 72	DB 72SS	DB 72SS305	3.94	4.88	3-15/16	4-7/8	100.0	123.8
DB 80*	DB 80SS	DB 80SS305	4.44	5.38	4-7/16	5-3/8	112.7	136.5
DB 88*	DB 88SS	DB 88SS305	4.94	5.88	4-15/16	5-7/8	125.4	149.2
DB 96	DB 96SS	DB 96SS305	5.44	6.38	5-7/16	6-3/8	138.1	161.9
DB 104	DB 104SS	DB 104SS305	5.94	6.88	5-15/16	6-7/8	150.8	174.7
DB 116	DB 116SS	DB 116SS305	6.38	7.63	6-3/8	7-5/8	161.9	193.7



Other sizes available upon request. Available in packed and bulk stock. Other packaging configurations available.  
\*Items not stocked. Special order only.



260 Schilling Circle  
Hunt Valley, MD, 21031, USA

Ph: 410-771-0380 • Fax: 410-771-5576

www.murraycorp.com • email: sales@murraycorp.com

# MURRAY

# MURRAY CORPORATION Clamping Solutions

## 5/16" Wide Worm Drive Clamp - SAE Type "M" Mini Series

Lightweight, low profile, compact design allows ease of installation in restricted applications. The 5/16 band width generates significant sealing pressure with relatively low installation torque levels. 300 series stainless steel band and housing.

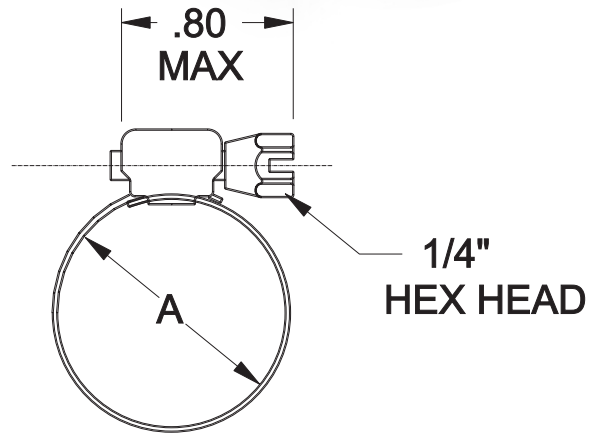
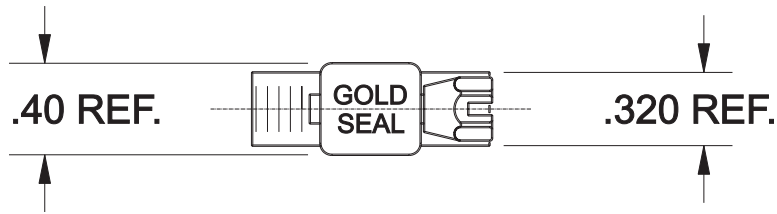

Size Ref.	Clamp Part No.			"A" Diameter Range					
	No.	Plated Screws	"400" Series Stainless Screws	"300" Stainless Screws	Decimals		Inches		Millimeters
3	MM 3	MM 3 SS	MMF 3 SS	.25	.50	1/4	1/2	6	13
4	MM 4	MM 4 SS	MMF 4 SS	.25	.63	1/4	5/8	6	16
6/8	MM 5	MM 5 SS	MMF 5 SS	.31	.91	5/16	29/32	8	23
10	MM 10	MM 10 SS	MMF 10 SS	.56	1.06	9/16	1-1/16	14	25

Available in packed and bulk stock. Other packaging configurations available. Clamps meet or exceed SAE J1508 Type M.



MURRAY

260 Schilling Circle  
Hunt Valley, MD, 21031, USA

Ph: 410-771-0380 • Fax: 410-771-5576  
www.murraycorp.com • email: sales@murraycorp.com



## Double-Wire Clamps - SAE Type "A"

Double sealing action, plated to protect against rust and corrosion.

Unique Swivel Nut:

- Nut is integral part of clamp to prevent loss.
- Nut remains perfectly aligned with screw.
- Standard zinc plated material; other plating types available.
- Standard wire diameter: 12 gauge (.1055 in +/- .003in) (2.68mm +/- .08mm)

Wire Grips are non-stocking parts. Produce and release policy requires firm purchase order and specific release dates.

Packaging: Bulk.- Minimum Lot sizes apply. - Patent Numbers 2,536,612 , 4,414 ,715 , 4,592,576



### Rated Ultimate Torque:

40in.lbs. min. (4.5Nm)

### Recommended Installation Torque:

20-25in.lbs. (2.3 - 2.8Nm)

SAE No.	Part Number	Inches		Millimeters	
		Open	Closed	Open	Closed
34	102100	1.06	0.94	26.9	23.9
36	102102	1.12	0.99	28.4	25.1
38	102104	1.19	1.06	30.2	26.9
40	102106	1.25	1.12	31.8	28.4
42	102108	1.31	1.16	33.3	29.5
44	102110	1.38	1.19	35.1	30.2
46	102112	1.44	1.25	36.6	31.8
48	102114	1.50	1.31	38.1	33.3
50	102116	1.56	1.38	39.6	35.1
52	102118	1.62	1.44	41.1	36.6
54	102120	1.69	1.50	42.9	38.1
56	102122	1.75	1.56	44.5	39.6
58	102124	1.81	1.62	46.0	41.1
60	102126	1.88	1.69	47.8	42.9
62	102128	1.94	1.75	49.3	44.5
64	102130	2.00	1.81	50.8	46.0
66	102200	2.06	1.88	52.3	47.8
68	102202	2.12	1.94	53.8	49.3
70	102204	2.19	1.97	55.6	50.0
72	102206	2.25	2.03	57.2	51.6
74	102208	2.31	2.12	58.7	53.8
76	102210	2.38	2.19	60.5	55.6
78	102212	2.44	2.25	62.0	57.2
80	102214	2.50	2.28	63.5	57.9
82	102216	2.56	2.34	65.0	59.4
84	102218	2.62	2.41	66.5	61.2
86	102220	2.69	2.47	68.3	62.7

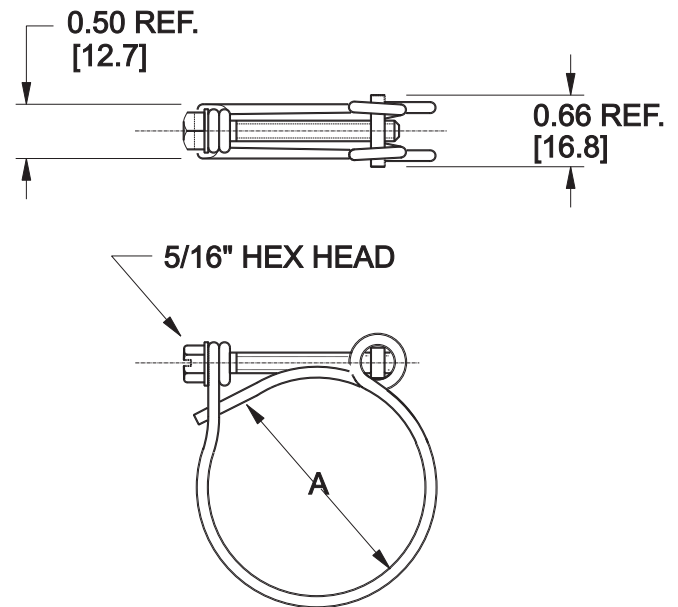

# MURRAY

# MURRAY CORPORATION Clamping Solutions

## Keystone Pinch Clamp (Welded) - SAE Type "J" (KS)

Murray KEYSTONE clamping products offer superior strength from 100% stainless steel.

### Common Clamping Applications:

**Irrigation • Water Supply • Fuel & Vapor lines • Beverage Supply Lines  
Car Wash Supply Lines • Dust Shields & Air Filters • Bundles of Cable**

Keystone Pinch Clamps are welded and are quick and easy to install, and provide a uniform, tamper proof seal. They are widely used on both soft hose and rigid plastic pipe. You will find these clamps anywhere you connect poly pipe. Ear clamps are excellent for use in a multitude of irrigation and water supply systems, on fuel and vapor lines, to attach dust shields and air filters, for beverage supply lines, for car wash supply lines, and for securing bundles of cable. When crimping with a hand tool, Murray's true Keystone geometry, located in the ear area, dramatically reduces miscrimps. Keystone Pinch clamps are 100% Stainless Steel.

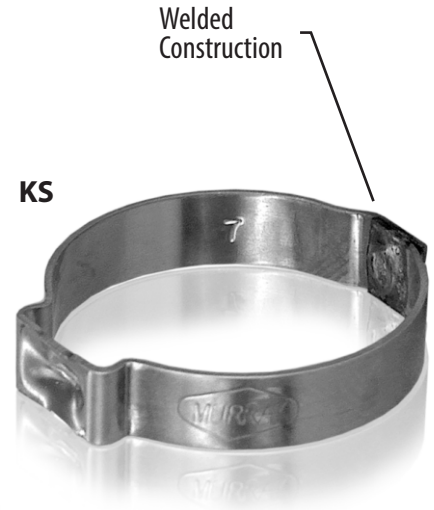

KS

Part Number	"A" Diameter Range			
	Metric		Decimals	
	Open	Closed	Open	Closed
KS 3119	11.9	10.0	.470	.395
KS 3133	13.3	11.4	.525	.450
KS 3150	15.0	12.5	.590	.490
KS 3157	15.7	13.2	.620	.520
KS 3161	16.1	13.6	.635	.535
KS 3165	16.5	14.0	.650	.550
KS 3173	17.3	14.7	.680	.580
KS 3185	18.5	16.0	.730	.630
KS 3198*	19.8	16.6	.780	.655
KS 3210*	21.0	17.9	.830	.705
KS 3222	22.2	19.1	.875	.750
KS 3236	23.6	20.5	.930	.805
KS 3256*	25.6	22.5	1.010	.885
KS 3271*	27.1	24.0	1.070	.945
KS 3301	30.1	27.0	1.185	1.060
KS 3216*	31.6	28.5	1.245	1.120
KS 3324	32.4	29.3	1.275	1.155
KS 3331*	33.1	30.0	1.300	1.180
KS 3346*	34.6	31.5	1.360	1.240
KS 3396	39.6	36.5	1.560	1.440
KS 3410*	41.0	37.9	1.615	1.490
KS 3425*	42.5	39.4	1.675	1.550
KS 3485*	48.5	45.5	1.910	1.787

Welded

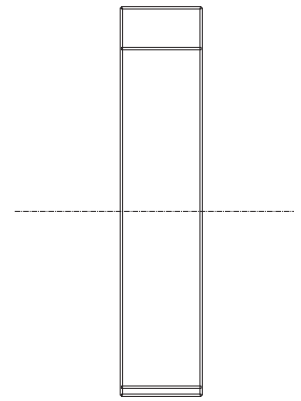
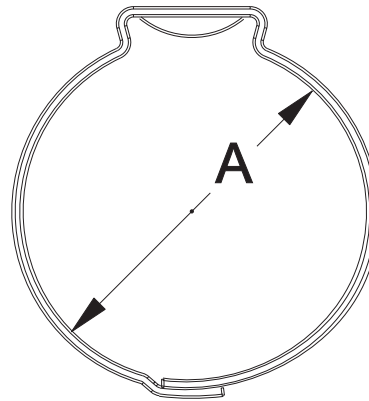
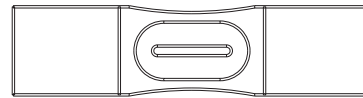

\*Popular irrigation sizes are available for immediate shipment packaged in poly bags. Please inquire on availability of other packaging configurations and lead time for other sizes. Other sizes, shapes and materials are available upon request, subject to minimum order quantities



MURRAY

260 Schilling Circle  
Hunt Valley, MD, 21031, USA

Ph: 410-771-0380 • Fax: 410-771-5576

www.murraycorp.com • email: sales@murraycorp.com

# MURRAY

# MURRAY CORPORATION Clamping Solutions

## Keystone Pinch Clamp (Mechanical) - SAE Type "J" (KSC)

Murray KEYSTONE clamping products offer superior strength from 100% stainless steel.

### Common Clamping Applications:

**Irrigation • Water Supply • Fuel & Vapor lines • Beverage Supply Lines**

**Car Wash Supply Lines • Dust Shields & Air Filters • Bundles of Cable**

Keystone Pinch Clamps are mechanically attached and are quick and easy to install, and provide a uniform, tamper proof seal. They are widely used on both soft hose and rigid plastic pipe. You will find these clamps anywhere you connect poly pipe. Ear clamps are excellent for use in a multitude of irrigation and water supply systems, on fuel and vapor lines, to attach dust shields and air filters, for beverage supply lines, for car wash supply lines, and for securing bundles of cable. Keystone Pinch clamps are 100% 300 Series Stainless Steel.



Mechanically Attached

Part Number	"A" Diameter Range			
	Metric		Decimals	
	Open	Closed	Open	Closed
KSC 3198*	19.8	16.6	.780	.655
KSC 3210*	21.0	17.9	.830	.705
KSC 3256*	25.6	22.5	1.010	.885
KSC 3271*	27.1	24.0	1.070	.945
KSC 3316*	31.6	28.5	1.245	1.120
KSC 3331*	33.1	30.0	1.300	1.180
KSC 3346*	34.6	31.5	1.360	1.240
KSC 3410*	41.0	37.9	1.615	1.490
KSC 3425*	42.5	39.4	1.675	1.550
KSC 3485*	48.5	45.5	1.910	1.787

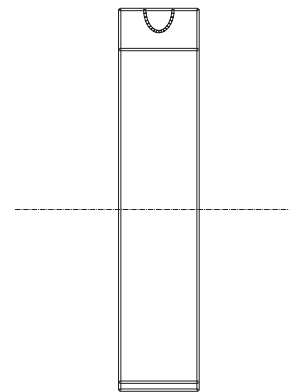
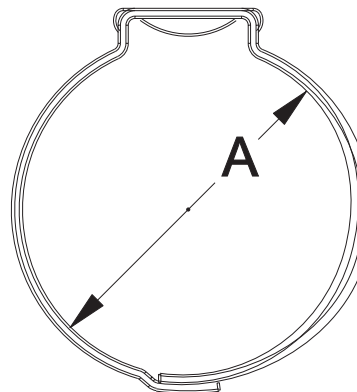
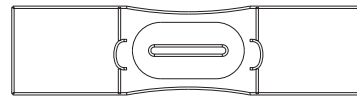

\*Popular irrigation sizes are available for immediate shipment packaged in poly bags. Please inquire on availability of other packaging configurations and lead time for other sizes. Other sizes, shapes and materials are available upon request, subject to minimum order quantities



260 Schilling Circle  
Hunt Valley, MD, 21031, USA

Ph: 410-771-0380 • Fax: 410-771-5576  
www.murraycorp.com • email: sales@murraycorp.com



# MURRAY

# MURRAY CORPORATION Clamping Solutions

## Seamless Pinch Clamps (KVG T)

These "Tongue and Groove" clamps offer 360° seamless fastening. Due to their seamless design and uniform compression sealing, these clamps are often used in the beverage, automotive, marine, and motorcycle industries. They are manufactured using 304 Stainless Steel and are perfect for poly and braided tubing.

- Murray Seamless Pinch Clamps provide 360 degrees of contact with your hose to help eliminate leaks
- Made with 304 Stainless Steel for high corrosion resistance to excel in difficult conditions like marine applications
- Our patented Crimp Lobes and our improved ear geometry helps eliminate miscrimps by keeping your crimping tool in place while helping create a 360 degree seal that will increase the performance of the connection.
- Ideal for use with OEM and Aftermarket applications in many markets such as: Automotive, Marine, Heavy Duty Truck, Beverage, Medical and many others.

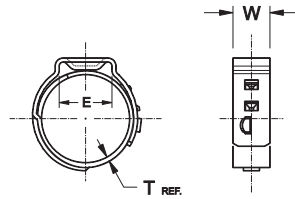

CLAMPS WITH OPEN DIA. (mm)	W (mm)	E (mm)	T (in)
7.0 - 11.8	5.0	5.5	.019
12.3 - 17.0	7.0	8.0	.022
18.5 - 66.0	7.0	10.0	.022



Many of our Seamless (KVG T) clamps offer our patented crimp lobe technology. This feature ensures that the crimping tool is properly positioned to help eliminate miscrimps which can result in leaks.

### 5 mm wide band

Part Number	Open Dia	Closed Dia
KVGT5056	5.6mm	4.4mm
KVGT5065	6.5mm	5.3mm
KVGT5070	7.0mm	5.8mm
KVGT5080	8.0mm	6.8mm
KVGT5087	8.7mm	7.0mm
KVGT5095	9.5mm	7.8mm
KVGT5100	10.0mm	8.3mm
KVGT5105	10.5mm	8.8mm
KVGT5109	10.9mm	9.2mm
KVGT5113	11.3mm	9.6mm
KVGT5118	11.8mm	10.1mm

### 7 mm wide band

Part Number	Open Dia	Closed Dia
KVGT7123	12.3mm	9.8mm
KVGT7133	13.3mm	10.8mm
KVGT7138	13.8mm	11.3mm
KVGT7140	14.0mm	11.5mm
KVGT7145	14.5mm	12.0mm
KVGT7153	15.3mm	12.8mm
KVGT7157	15.7mm	13.2mm
KVGT7162	16.2mm	13.7mm
KVGT7170	17.0mm	14.5mm
KVGT7180	18.0mm	15.5mm
KVGT7185	18.5mm	16.0mm
KVGT7192	19.2mm	16.0mm
KVGT7198	19.8mm	16.6mm
KVGT7210	21.0mm	17.8mm
KVGT7220	22.0mm	18.8mm
KVGT7226	22.6mm	19.4mm
KVGT7235	20.3mm	23.5mm
KVGT7241	24.1mm	20.9mm
KVGT7256	25.6mm	22.4mm
KVGT7271	27.1mm	23.9mm
KVGT7286	28.6mm	25.4mm
KVGT7455	45.5mm	42.3mm

\* Patented crimp lobes are currently available on select sizes. Please contact us for details.

## Automotive



## Beverage



## Marine



## Heavy Duty Truck



260 Schilling Circle  
Hunt Valley, MD, 21031, USA

Ph: 410-771-0380 • Fax: 410-771-5576  
www.murraycorp.com  
email: sales@murraycorp.com

# MURRAY

# MURRAY CORPORATION Clamping Solutions

## Heavy Duty Seamless PEX Pipe Clamps For use with "DZR" Brass and Plastic PEX Fittings

These patented heavy duty "Tongue and Groove" clamps offer 360° stainless fastening and meet or exceed ASTM F-2098 requirements. Due to their heavy-duty 304 stainless steel construction as well as their seamless design and uniform compression sealing, these cutting edge clamps were designed primarily for PEX (cross-linked polyethylene) PAP (PEX Aluminum PEX), PERT (Polyethylene Raised Temperature) but has numerous alternate uses.

Manufactured with patented "Non-Slip" tool crimp lobes on both ends of the ear, Murray's heavy-duty seamless PEX clamps are the best at preventing mis-crimps and slip-offs as well as holding fast under the worst conditions. Murray Corporation's clamping products are subjected to rigorous environmental testing to ensure maximum reliability and longevity in adverse conditions.



NSF Listed to ASTM F2098

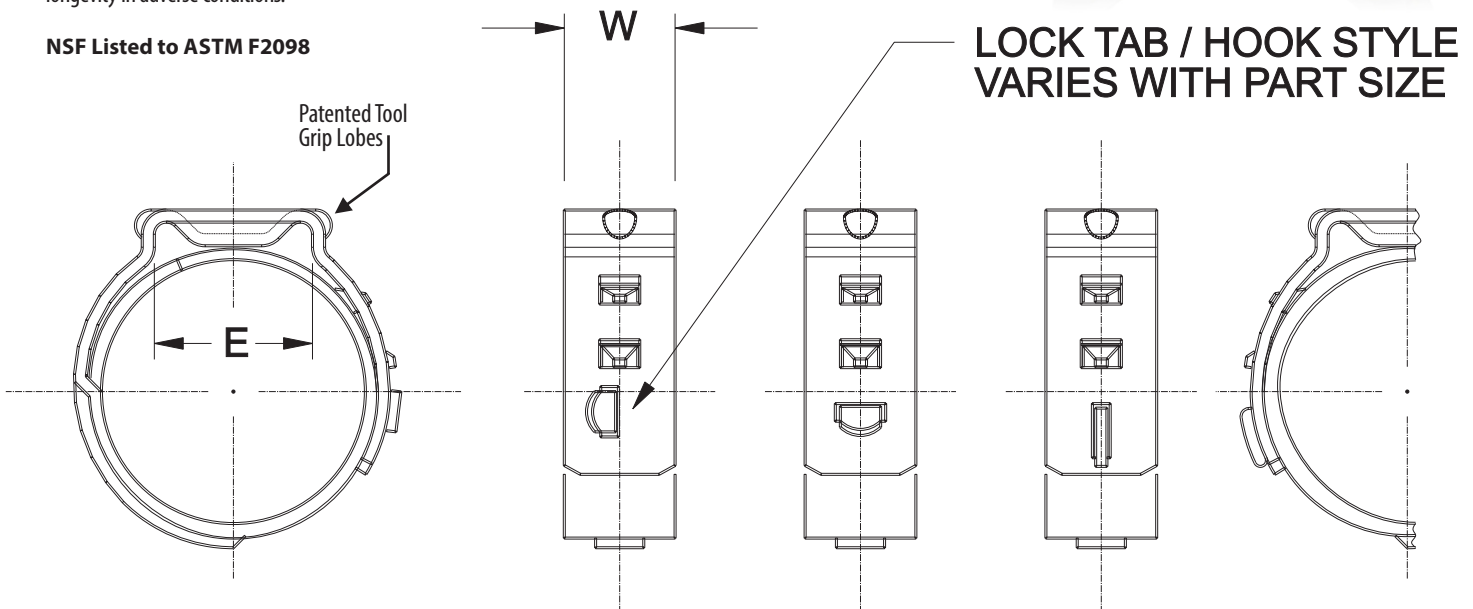

LOCK TAB / HOOK STYLE VARIES WITH PART SIZE

PEX TUBE SIZE	W	E
3/8	7mm (0.276)	8mm
1/2	7mm (0.276)	10mm
5/8	9mm (0.354)	10 mm
3/4	9mm (0.354)	10mm
1"	10mm (0.394)	10mm



All of our PEX clamps offer our patented crimp lobe technology. This feature ensures that the crimping tool is properly positioned to help eliminate miscrimps which can result in leaks.

Part Number	PEX Tube Size	Width (W)	Open Dia.	Closed Dia.	Open Dia. Inches	Closed Dia. Inches
PEX 133	3/8"	7.0mm	13.3mm	10.8mm	0.524	0.424
PEX 175	1/2"	7.0mm	17.5mm	14.3mm	0.689	0.564
PEX 206	5/8"	9.0mm	20.6mm	17.4mm	0.811	0.686
PEX 233	3/4"	9.0mm	23.3mm	20.1mm	0.917	0.791
PEX 296	1"	10.0mm	29.6mm	26.4mm	1.165	1.039



Other sizes available upon request. Available in packed and bulk stock. Other packaging configurations available.

Use "Everlast" PEX Clamps with yellow brass fittings having a zinc content greater than 15%.



260 Schilling Circle  
Hunt Valley, MD, 21031, USA

Ph: 410-771-0380 • Fax: 410-771-5576

www.murraycorp.com • email: sales@murraycorp.com





# MURRAY

# MURRAY CORPORATION Clamping Solutions

## **NEW Everlast 20 Heavy Duty Seamless Clamps**

"New clamping technology" Murray Heavy Duty Seamless Clamp suitable for use in marine and other aggressive water and atmospheric conditions. Resists salt and bilge water, common household cleaning agents, industrial/mining elements. Also resists clamp damage resulting from brass fitting dezincification in pex plumbing systems.



Many of our Pex (PEX) and Seamless (KVGT) clamps and Keystone (KSC) offer our patented crimp lobe technology. This feature ensures that the crimping tool is properly positioned to help eliminate miscrimps. Miscrimps often lead to leaks.



**MURRAY**

260 Schilling Circle  
Hunt Valley, MD, 21031, USA

Ph: 410-771-0380 • Fax: 410-771-5576  
[www.murraycorp.com](http://www.murraycorp.com) • email: [sales@murraycorp.com](mailto:sales@murraycorp.com)



# MURRAY

# MURRAY CORPORATION "Create-A-Clamp"

## "Create-A-Clamp" Clamp Making Kit

This kit contains 10 ft. of banding, 6 adjustable fasteners, and 6 band splices for making any size clamp you need. Instead of you adjusting your work to the size of the clamp, let the clamp adjust to you and make your work easier and faster. Create a Clamp Kit can be used to create permanent or temporary clamps and can be used for almost anything.

- All-300 Grade Stainless Steel
- 10 ft. Of Banding Material
- Makes Up To Six Clamps
- 9/16" Wide Band
- 5/16" Slotted Hex Head Screw
- Torque Rate is 100 in-lb Ultimate Torque

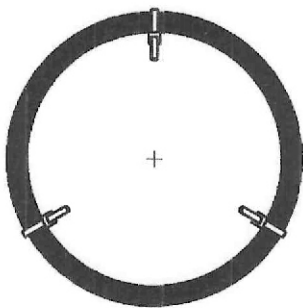

Preslotted Band Stock - 10 Foot Coil  
Quantity = 1 Per Package

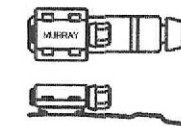

Worm Drive Assembly with Screw  
Quantity = 6 Per Package



Worm Drive Band Flat  
Quantity = 6 Per Package



Short Band Splice  
Quantity = 6 Per Package

MURRAY

260 Schilling Circle  
Hunt Valley, MD, 21031, USA

Ph: 410-771-0380 • Fax: 410-771-5576  
www.murraycorp.com • email: sales@murraycorp.com



# MURRAY

# MURRAY CORPORATION Clamping Solutions

## T-Bolt Clamps - SAE Type "TB"

Murray T-Bolt band clamps are designed to provide connections without leaks. They are typically installed in truck exhaust or air inlet and water hoses, motorcycle exhaust systems, marine applications, irrigation system hoses, water pump hoses and filter bags. Band edges are rounded to protect the hose.

**TB series** clamps use a plated steel bolt and self-locking nut. The balance of the components are made from 300 series stainless steel.

**TBSS series** clamps are made entirely from 300 series stainless steel. Clamps are also available in 316 Stainless Steel as special order items.

Maximum service temperature for locknut is 250° (F).

High temp locknuts by special order.



### Rated Ultimate Torque:

Plated Steel Bolt & Nut: 90in.lbs. min. (10.2Nm)  
300 Series Stainless Bolt & Nut: 75in.lbs. min. (8.5Nm)

### Recommended Installation Torque:

Plated Steel Bolt & Nut: 50-60in.lbs. (5.6 - 6.8Nm)  
300 Series Stainless Bolt & Nut: 50-60in.lbs. (5.6 - 6.8Nm)

Double Plated Bolt & Nut	"300" Series Stainless	Nominal	Inches		Millimeters		
			Min.	Max.	Nominal	Min.	Max.
TB156	TB156SS	1.50	1.31	1.56	38	33	40
TB187	TB187SS	1.75	1.62	1.87	44	41	47
TB206	TB206SS	2.00	1.81	2.06	51	46	52
TB225	TB225SS	2.15	1.94	2.25	55	49	57
TB237	TB237SS	2.25	2.06	2.37	57	52	60
TB250	TB250SS	2.40	2.19	2.50	61	56	64
TB262	TB262SS	2.50	2.31	2.62	64	59	67
TB287	TB287SS	2.75	2.56	2.87	70	65	73
TB312	TB312SS	3.00	2.81	3.12	76	71	79
TB337	TB337SS	3.25	3.06	3.37	83	78	86
TB359	TB359SS	3.50	3.28	3.59	89	83	91
TB387	TB387SS	3.78	3.56	3.87	96	90	98
TB394	TB394SS	3.85	3.63	3.94	98	92	100
TB412	TB412SS	4.00	3.81	4.12	102	97	105
TB437	TB437SS	4.25	4.06	4.37	108	103	111
TB462	TB462SS	4.50	4.31	4.62	114	109	117
TB487	TB487SS	4.75	4.56	4.87	121	116	124
TB512	TB512SS	5.00	4.81	5.12	127	122	130
TB537	TB537SS	5.25	5.06	5.37	133	129	136
TB562	TB562SS	5.50	5.31	5.62	140	135	143
TB587	TB587SS	5.75	5.56	5.87	146	141	149
TB612	TB612SS	6.00	5.81	6.12	152	148	155
TB637	TB637SS	6.25	6.06	6.37	159	154	162
TB662	TB662SS	6.50	6.31	6.62	165	160	168
TB687	TB687SS	6.75	6.56	6.87	171	167	174
TB712	TB712SS	7.00	6.81	7.12	178	173	181
TB737	TB737SS	7.25	7.06	7.37	184	179	187
TB762	TB762SS	7.50	7.31	7.62	191	186	194
TB787	TB787SS	7.75	7.56	7.87	197	192	200
TB812	TB812SS	8.00	7.81	8.12	203	198	206
TB837	TB837SS	8.25	8.06	8.37	210	205	213
TB919	TB919SS	9.00	8.61	9.19	229	219	233
TB1113	TB1113SS	11.00	10.55	11.13	279	268	283
TB1313	TB1313SS	13.00	12.55	13.13	330	319	334

Other sizes are available. Please contact Murray for more information.

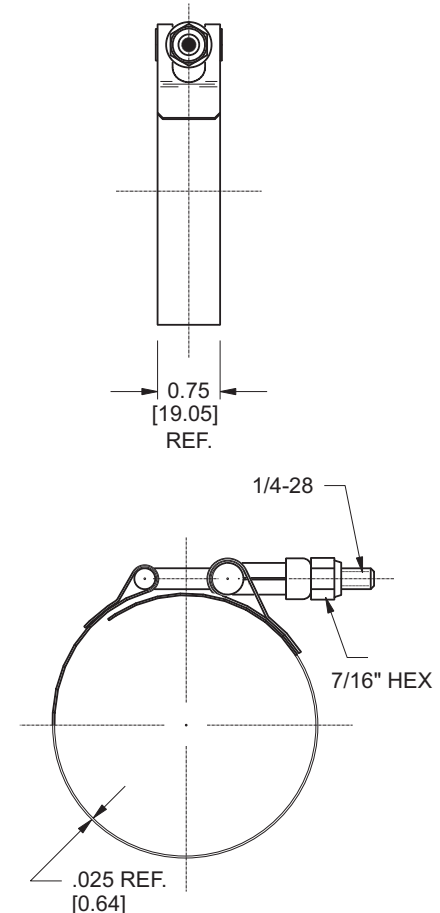

260 Schilling Circle  
Hunt Valley, MD, 21031, USA

Ph: 410-771-0380 • Fax: 410-771-5576  
www.murraycorp.com • email: sales@murraycorp.com



# MURRAY

# MURRAY CORPORATION Clamping Solutions

## Spring-Loaded T-Bolt Clamps - SAE Type "SLTB"

Murray spring-loaded clamps are designed to compensate for the expansion and contraction of hose caused by temperature and/or hose cold flow. Typical installations include silicone hoses on charge air cooling/air to air, after cooling systems, and primary engine coolant systems. Locknut rated temp. 250°F

**TBLS series** clamps use a plated steel self-locking nut, bolt and spring. The balance of the components are made from 300 series stainless steel. Band edges are rounded to protect hoses.

Maximum service temperature for locknut is 250° (F).



**Note:** Coil springs should not be compressed to solid at installation. Make sure the nut is positioned approximately one to two turns from solid. This allows the clamp to expand and contract.

**Rated Ultimate Torque:**

Plated Steel Bolt & Nut: 90in.lbs. min. (10.2Nm)

**Recommended Installation Torque:**

Plated Steel Bolt & Nut: 50-60in.lbs. (5.6 - 6.8Nm)

300 Series Stainless Bolt & Nut: 50-60in.lbs. (5.6 - 6.8Nm)

Double Plated Nut & Bolt Spring	Inches			Millimeters		
	Nominal	Min.	Max.	Nominal	Min.	Max.
TBLS132	1.25	1.12	1.32	32	28	34
TBLS145	1.40	1.26	1.45	36	32	37
TBLS169	1.60	1.50	1.69	41	38	43
TBLS212	2.00	1.82	2.12	51	46	54
TBLS236	2.25	2.06	2.36	57	52	60
TBLS261	2.50	2.31	2.61	64	59	66
TBLS286	2.75	2.56	2.86	70	65	73
TBLS308	3.00	2.78	3.08	76	71	78
TBLS333	3.25	3.03	3.33	83	77	85
TBLS358	3.50	3.28	3.58	89	83	91
TBLS383	3.75	3.53	3.83	95	90	97
TBLS408	4.00	3.78	4.08	102	96	104
TBLS433	4.25	4.03	4.33	108	102	110
TBLS458	4.50	4.28	4.58	114	109	116
TBLS483	4.75	4.53	4.83	121	115	123
TBLS508	5.00	4.78	5.08	127	121	129
TBLS533	5.25	5.03	5.33	133	128	135
TBLS558	5.50	5.28	5.58	140	134	142
TBLS586	5.75	5.56	5.86	146	141	149
TBLS608	6.00	5.78	6.08	152	147	154
TBLS633	6.25	6.03	6.33	159	153	161
TBLS655	6.50	6.25	6.55	165	159	166
TBLS686	6.75	6.56	6.86	171	167	174
TBLS708	7.00	6.78	7.08	178	172	180
TBLS736	7.25	7.06	7.36	184	179	187
TBLS758	7.50	7.28	7.58	191	185	193
TBLS783	7.75	7.53	7.83	197	191	199
TBLS811	8.00	7.81	8.11	203	198	206
TBLS858	8.50	8.28	8.58	216	210	218
TBLS880	8.75	8.50	8.80	222	216	224

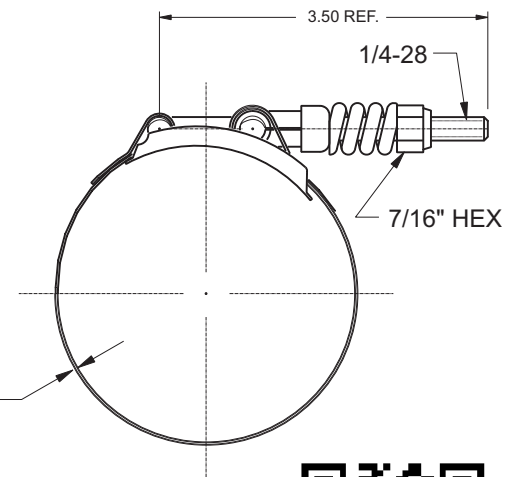
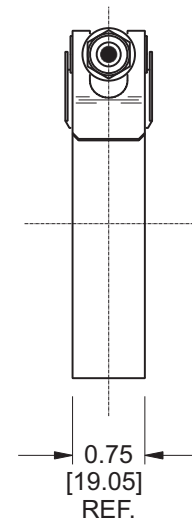

Other sizes, configurations and materials are available. Please contact the sales department for more information.  
All items are packaged 50 pieces per carton.  
Spring rate = 1900 lbs/in. capable of exerting a 300 lb. band load.

.025 REF.  
[0.64]



260 Schilling Circle  
Hunt Valley, MD, 21031, USA

Ph: 410-771-0380 • Fax: 410-771-5576

www.murraycorp.com • email: sales@murraycorp.com

# MURRAY

# MURRAY CORPORATION Clamping Solutions

## Type "F" Quick Release Clamp

Band and housing are 200 Series Stainless Steel with a 200 Series Stainless screw. These quick release worm drive clamps are easy to install and remove due to the swivel action locking of the screw. This clamp has a large clamping range which makes them very versatile. It is used for closed system installations where the clamp must be opened to be fitted.

Part Number	Diameter (Inch)		Diameter (mm)	
	Open	Closed	Open	Closed
QR 104 S2	7.00	2.00	171	51
QR 128 S2	8.50	2.00	216	51
QR 152 S2	10.00	2.00	254	51
QR 188 S2	12.25	2.00	311	51
QR 232 S2	15.00	2.00	381	51
QR 258 S2	16.63	2.00	422	51
QR 288 S2	18.50	2.00	470	51
QR 312 S2	20.00	2.00	508	51

Other sizes available

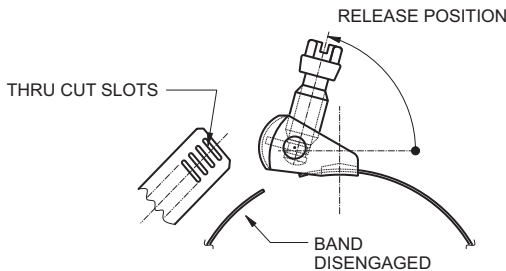
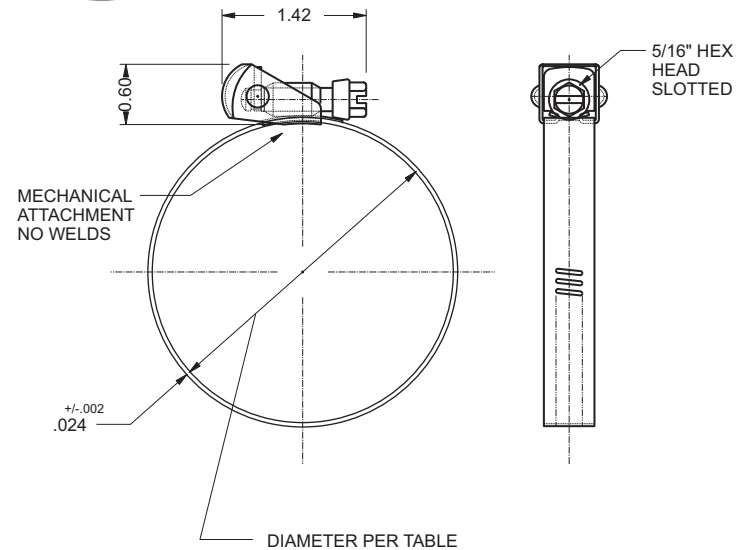
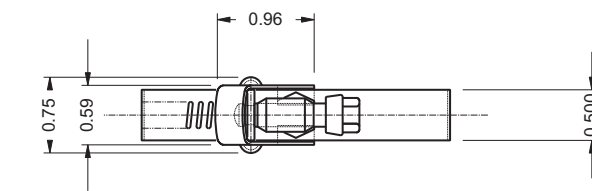

260 Schilling Circle  
Hunt Valley, MD, 21031, USA

Ph: 410-771-0380 • Fax: 410-771-5576  
www.murraycorp.com • email: sales@murraycorp.com



# MURRAY

# MURRAY CORPORATION Clamp Crimping Tools

## TOOLS

### Murray Clamp Crimping Tools



**A2000 Keystone Crimp Tool**  
(Short Handle)  
For KS, KSC, KVG T



**A2005 Keystone Crimp Tool**  
(Long Handle)  
For KS, KSC, KVG T



**A2100 Front Side Jaw Crimp Tool**  
For KS, KSC, KVG T



**A3000 Pneumatic Keystone Crimp Tool**  
For KS, KSC, KVG T



**A4000 Ratchet Action Crimp Tool**  
For Heavy Duty  
**Seamless Pinch Clamp**  
For PEX Pipe applications  
and all other Pinch Clamps



**A4005 Ratchet Action H.D. Long Handle Crimp Tool**  
For Heavy Duty Seamless  
Pinch Clamps Mostly used on  
3/4" and 1" sizes.  
For PEX Pipe applications.



260 Schilling Circle  
Hunt Valley, MD, 21031, USA

TOOLS

Ph: 410-771-0380 • Fax: 410-771-5576

www.murraycorp.com • email: sales@murraycorp.com



# MURRAY

# MURRAY CORPORATION Industrial Thread Repair Kit

## TOOLS

### Repairs Damaged Threads Fast & Easy!

The Murray Tools' Split Die Thread Repair Tool reduces the need to find or buy replacement fasteners or threaded components and provides the peace of mind of knowing the repaired fastener is the original. Murray Tools' Split Die Thread Repair Tool lets you start on threads which are intact, to eliminate the possibility of cross threading.

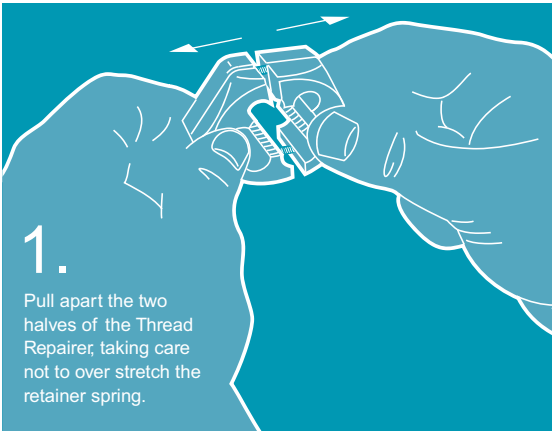

1.

Pull apart the two halves of the Thread Repairer, taking care not to over stretch the retainer spring.

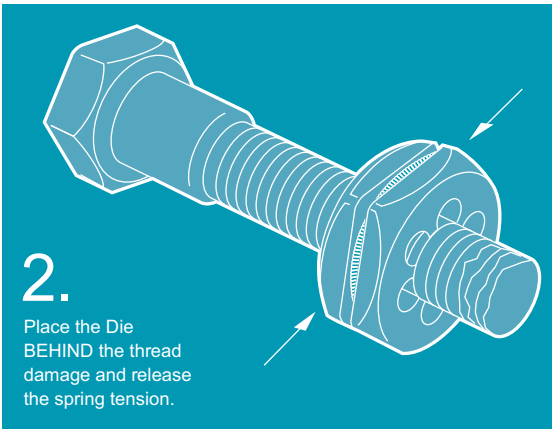

2.

Place the Die BEHIND the thread damage and release the spring tension.



3.

Turn the die COUNTER CLOCKWISE using a standard 6-point socket until repair is complete.

## Easy Thread Repair

Unique patented design saves you time by avoiding the need for major disassembly or teardown of equipment to remove a damaged stud or hard to reach damaged bolt.

- Repairs damaged bolts faster than conventional thread repair tools.
- Eliminates the need for aftermarket replacement parts that are often too long, too short or the wrong hardness.
- Built for industrial use and made to withstand the conditions faced by the U.S. Military.
- Dies are designed and built to last, and have undergone thorough testing and inspections.
- Heat-treated, hardened, high-grade carbon steel meets the highest quality standards.
- Use deep well 6-point socket and/or box wrenches for ideal performance.

**Ideal for mechanics, machinists, and engineers.**

**Automotive • Industrial  
Marine • Agricultural/Tractors  
Mining • Manufacturing**



100% Made in the USA  
PATENTED



Available in both  
Metric and  
American sizes.



# MURRAY

260 Schilling Circle  
Hunt Valley, MD, 21031, USA

TOOLS

Ph: 410-771-0380 • Fax: 410-771-5576

www.murraycorp.com • email: sales@murraycorp.com

# MURRAY

# MURRAY CORPORATION

## Murray Tools Tri Gage

### TOOLS

## Measures Bolts & Threads Accurately to Save Time!

This time saving tool measures the bolt diameter and thread pitch for accurate replacement of bolts. Murray Tools' Bolt Sizer Thread Pitch Gage is military grade, with machine stamped markings for durability.

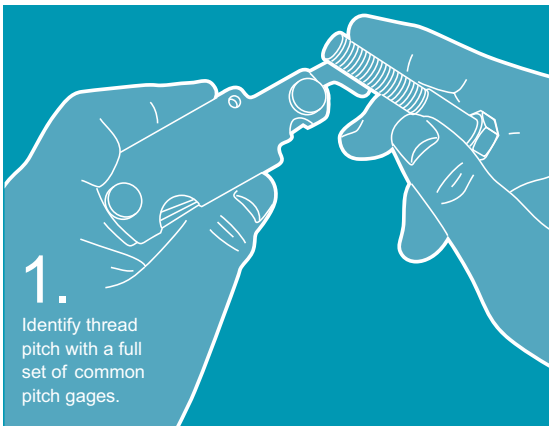

**1.**  
Identify thread pitch with a full set of common pitch gages.

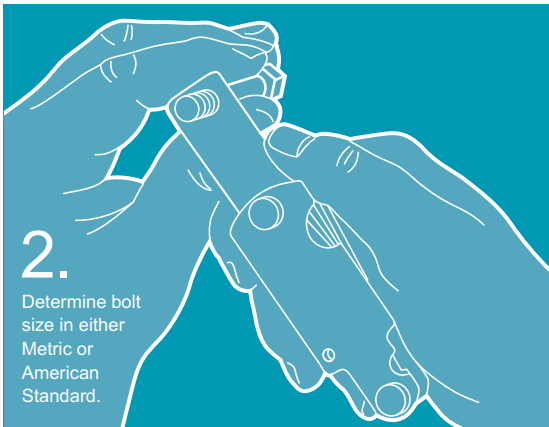

**2.**  
Determine bolt size in either Metric or American Standard.

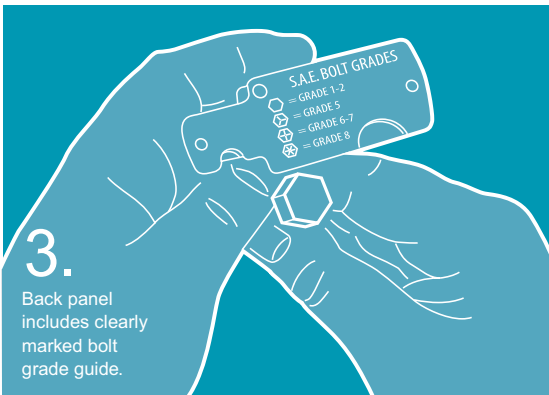

**3.**  
Back panel includes clearly marked bolt grade guide.

## Fast & Easy

Quickly identifies the correct bolt needed to get the job done right

- High-grade stainless steel, so it's rust free.
- Tension wheels are ribbed, for a non-slip grip.
- Finger notches are easy to use, for a better grip.
- Pre-drilled to put on your tool belt.
- Rounded edges to prevent injury.
- Bolt sizing blades are marked with bolt diameter and wrench size.

Ideal for machinists, engineers, mechanics, and do-it-yourselfers.

**Automotive • Industrial • Marine • Mining • Construction**

### Murray Tools Tri Gage

Description	Part Numbers	Specs/Contents
American Tri Gage	G-CA14-2-1	Bolt Diameter-1/4, 5/8, 3/8, 7/16, 1/2, 9/16, 5/8, 3/4, 7/8, 1 Thread Pitches 8, 9, 10, 11, 12, 13, 14, 16, 18, 20, 24, 28
Metric Tri Gage	G-CM5-2-24	Bolt Diameter-5, 6, 8, 9, 10, 11, 12, 14, 16, 18, 20, 24, 28 Thread Pitches -.75, .8, 1.0, 1.25, 1.3, 1.4, 1.5, 1.6, 1.75, 1.8, 2.0, 2.5, 3.0

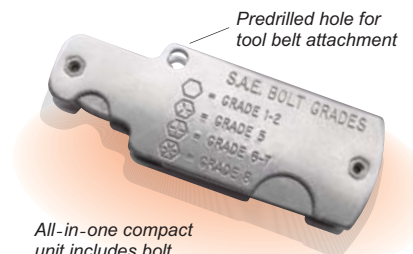

All-in-one compact unit includes bolt sizing blades from 1/4" to 1" SAE sizes and 5mm to 24mm for Metric sizes and full set of common pitch gages.

Available in both Metric and American sizes.

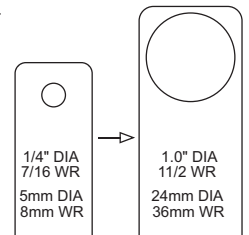

100% Made in the USA PATENTED



260 Schilling Circle  
Hunt Valley, MD, 21031, USA

TOOLS

Ph: 410-771-0380 • Fax: 410-771-5576

www.murraycorp.com • email: sales@murraycorp.com

# MURRAY

# MURRAY CORPORATION

## Industrial Thread Repair Kit

### TOOLS

#### Murray Tools Thread Die Kits and Individual Dies

Description	Part Numbers	Kit Contents
SAE Small Kit	F-CKA6-14-2-38	1/4-20, 1/4-28, 5/16-18, 5/16-24, 3/8-16, 3/8-24
SAE Medium Kit	F-CKA6-716-2-916	7/16-14, 7/16-20, 1/2-13, 1/2-20, 9/16-12, 9/16-18
SAE Large Kit	FCKA6-12-2-58	1/2-13, 1/2-20, 9/16-12, 9/16-18, 5/8-11, 5/8-18
SAE X Large Kit	FCKA6-34-2-1	3/4-10, 3/4-16, 7/8-9, 7/8-14, 1-8, 1-14
Metric Small Kit	FCKM6-580-2-9125	5mm-8, 6mm-1, 8mm-1, 8mm-1.25, 9mm-1, 9mm-1.25
Metric Medium Kit	FCKM6-10100-2-12150	10mm-1, 10mm-1.25, 10mm-1.5, 11mm-1.5, 12mm-1.25, 12mm-1.5
Metric Large Kit	FCKM6-12175-2-24300	12mm-1.75, 14mm-1.25, 14mm-1.5, 16mm-2.0, 20mm-2.5, 24mm-3.0
Wheel Stud Repair Kit	F-CKAM6-AWL	1/2-20, 9/16-18, 12mx1.25, 12mx1.5, 12mx1.75, 14mx1.50
SAE Master Kit	F-CKA20-142	All of the SAE sizes listed in the chart below
Metric Master Kit	F-CKM18-5224	All of the Metric sizes listed in the chart below



100% Made in the USA  
PATENTED

Other sizes and kits may be available upon special request.

#### Individual Dies

Description	Part Numbers	Socket Size for Installation
SAE/American Sizes of Dies		
1/4-20 NC	F-CA14-20	1 inch
1/4-28 NF	F-CA14-28	1 inch
5/16-18 NC	F-CA516-18	1 inch
5/16-24 NF	F-CA516-24	1 inch
3/8-16 NC	F-CA38-16	1 inch
3/8-24 NF	F-CA38-24	1 inch
7/16-14 NC	F-CA716-14	1 inch
7/16-20 NF	F-CA716-20	1 inch
1/2-13 NC	F-CA12-13	1 inch
1/2-20 NF	F-CA12-20	1 inch
9/16-12 NC	F-CA916-12	1-7/16 in.
9/16-18 NF	F-CA916-18	1-7/16 in.
5/8-11 NC	F-CA58-11	1-7/16 in.
5/8-18 NF	F-CA58-18	1-7/16 in.
3/4-10 NC	F-CA34-10	1-7/16 in.
3/4-16 NF	F-CA34-16	1-7/16 in.
7/8-9 NC	F-CA78-9	1-7/8 in.
7/8-14 NF	F-CA78-14	1-7/8 in.
1-8 NC	F-CA1-8	1-7/8 in.
1-14 NF	F-CA1-14	1-7/8 in.

Description	Part Numbers	Socket Size for Installation
Metric Sizes of Dies		
5MM-.80	F-CM5-80	1 inch
6MM-1.00	F-CM6-100	1 inch
8MM-1.00	F-CM8-100	1 inch
8MM-1.25	F-CM8-125	1 inch
9MM-1.00	F-CM9-100	1 inch
9MM-1.25	F-CM9-125	1 inch
10MM-1.00	F-CM10-100	1 inch
10MM-1.25	F-CM10-125	1 inch
10MM-1.50	F-CM10-150	1 inch
11MM-1.50	F-CM11-150	1 inch
12MM-1.25	F-CM12-125	1 inch
12MM-1.50	F-CM12-150	1 inch
12MM-1.75	F-CM12-175	1 inch
14MM-1.25	F-CM14-125	1-7/16 in.
14MM-1.50	F-CM14-150	1-7/16 in.
16MM-2.00	F-CM16-200	1-7/16 in.
20MM-2.50	F-CM20-250	1-7/8 in.
24MM-3.00	F-CM24-300	1-7/8 in.



260 Schilling Circle  
Hunt Valley, MD, 21031, USA

TOOLS

Ph: 410-771-0380 • Fax: 410-771-5576

www.murraycorp.com • email: sales@murraycorp.com

# MURRAY

## MURRAY CORPORATION Nut Runner & Clamp Key

### "Flexible Clamp Driver"/Nut Runner A6000000C



Provides easy access for installation or removal in tight spaces and odd angles. Perfect for working on crowded engine compartments and plumbing repair applications. The reversible socket works with both standard 5/16" size and mini 1/4" hose clamp screws.

- 90 degree access
- Non-slip handle
- Hollow 6" flexible shaft
- Nickel plated steel

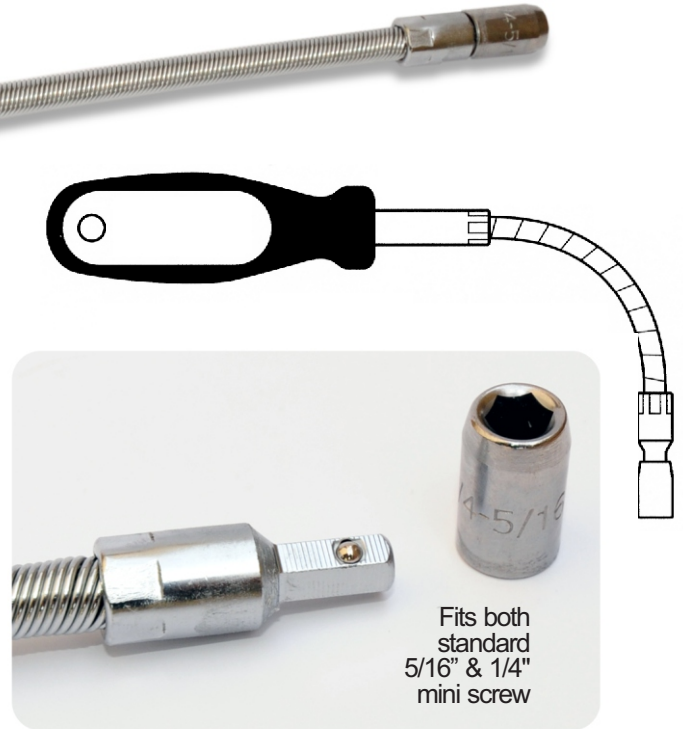

Fits both  
standard  
5/16" & 1/4"  
mini screw

### Murray Clamp Key 90003100P10

- Murray Clamp Key makes installation quick with a simple twist of the hand.
- Easy to remove/replace and is reusable.
- Produces an installation torque of 30-35 in. lbs.
- Compatible with all Murray Clamps that use a 5/16 inch screw.



MURRAY

260 Schilling Circle  
Hunt Valley, MD, 21031, USA

Ph: 410-771-0380 • Fax: 410-771-5576  
www.murraycorp.com • email: sales@murraycorp.com